

# Walk-behind Floor Scrubber

Instructions for operation and maintenance

## CATALOGUE

List	1
Optional parts	1
INTRODUCTORY COMMENT	1
TECHNICAL DESCRIPTION	2
SYMBOLS USED IN THE MANUAL	3
GENERAL SAFETY REGULATIONS	4
I、 MACHINE PREPARATION	
HANDLING THE PACKED MACHINE	5
HOW TO UNPACK THE MACHINE	5
OVERALL INTRODUCTION	6
INSERTING THE BATTERIES	7
CONNECTING THE BATTERIES	7
TYPE OF BATTERY	
BATTERY MAINTENANCE	7
BATTERY DISPOSAL	8
RECHARGING THE BATTERIES	8
VOLTMETER	8
ASSEMBLING THE SQUEEGEE	9
ADJUSTING THE HEIGHT OF SQUEEGEE	9
RECOVERY TANK、 SOLUTION TANK、 CLEAN WATER	10
ASSEMBLING THE BRUSH	11
II、 WORK	
PREPARING TO WORK	12
WORKING	12
OVERFLOW DEVICE	13
AT THE END OF THE WORK	13
III、 DAILY MAINTENANCE	
CLEANING THE RECOVERY TANK	14
CLEANING THE SUCTION FILTER	14
CLEANING THE SQUEEGEE	14
DISASSEMBLING THE BRUSH	14
CLEANING THE BATTERY BOX	15
IV、 WEEKLY MAINTENANCE	15
V、 TROUBLE SHOOTING	17
VI、 CHOOSING AND USING THE BRUSHES	18

**List**

**Standard Packing List**

order	name	unit	quantity
1	Machine	set	1
2	Charge cable	set	1
3	Battery cable	piece	1
4	Squeegee assembly	set	1
5	Suction pipe	piece	1
6	Manual	piece	1
7	QC certificate	piece	1



**Optional parts**

Pad holder 21 inch

Front squeegee blade rubber grease proof

Rear squeegee blade rubber grease proof

**INTRODUCTORY COMMENT**

Floor scrubber-dryer, via the mechanical action of the rotating brush and the chemical action of a water/detergent solution, can clean any type of flooring. As it advances, it also collects the dirt removed and the detergent solution not absorbed by the floor. Even the best machines will only work well if used correctly and kept in good working order. We therefore suggest you read this instruction booklet carefully and read it again whenever difficulties arise while using the machine. If necessary, remember that our assistance service (organized in collaboration with our dealers) is always available for advice or direct intervention.

**TECHNICAL DESCRIPTION**

Working Width	mm	560
Squeegee Width	mm	850
Max. Forward Speed	Km/h	4.5
Max. Capacities	m <sup>2</sup> /H	2500
Working Time	h	3-5H
Brush Pressure	kg	40
Brush RPM	rpm	155
Brush Motor	V/W	24V/550W
Suction Motor	V/W	24V/450W
Drive Motor	V/W	24V/300W
Solution Tank	L	60
Recovery Tank	L	65
Dimensions LWH	mm	1225*870*1135
Batteries	V	24V/100AH
Batteries Weight	kg	2*35
Net weight	kg	155

### SYMBOLS USED IN THE MANUAL



Attention



Recycle



Manual



Information



Watch Your Hand



Warning corrosion



Warning injure hand



Caution shock



No open flames



Dangerous waste



Caution Danger of exhalation of gas



Lifting means

## GENERAL SAFETY REGULATIONS

**The regulations below must be carefully followed in order to avoid harm to the operator and damage to the machine.**

- ◆ Read the labels on the machine carefully. Do not cover them for any reason and replace them immediately if they become damaged.
- ◆ The machine must be used exclusively by authorized, trained personnel.
- ◆ During the working of the machine, pay attention to other people and especially to children.
- ◆ Do not mix different types of detergent as this may produce harmful gases.
- ◆ Do not pack the machine when there is residual liquid in it.
- ◆ The storage temperature must be between -25°C and +55°C.
- ◆ Conditions of use: room temperature between 0°C and 40°C with relative humidity between 30 and 95%.
- ◆ Do not use the machine in an explosive atmosphere.
- ◆ Do not use the machine as a means of transport.
- ◆ Do not use acid solutions, which may damage the machine or harm the operator.
- ◆ Avoid working with the brushes when the machine is standing still, so as not to damage the floor.
- ◆ Do not vacuum inflammable liquids
- ◆ Do not use the device to collect dangerous powders.
- ◆ In the event of a fire, use a powder extinguisher. Do not use water.
- ◆ Do not knock against shelving or scaffolding, where there is a danger of falling objects.
- ◆ Select the operating speed according to the traction status.
- ◆ Do not use the machine on surfaces with an inclination greater than the one shown on the plate.
- ◆ When not in use, remove the keys and place the machine in a proper way to keep still.
- ◆ The machine is designed to carry out the washing and drying operations simultaneously. Different operations should only be carried out in areas where the passage of unauthorized persons is prohibited. Signal the presence of damp floors with suitable signs.
- ◆ If the machine does not work properly, check this is not caused by failure to carry out routine maintenance. Otherwise, request the intervention of your dealer After-sale Service Centre.
- ◆ If you need to replace any components, request the ORIGINAL spare parts from a dealer or Authorized Retailer..
- ◆ Only use the brushes supplied with the device, or those specified in the Use and Maintenance Manual.
- ◆ Pull down the emergency brake immediately when there is an operation risk.
- ◆ Before carrying out any maintenance work, switch off the machine and disconnect the battery connector.

- ◆ Make sure the whole electrical connection is recovered after maintenance.
- ◆ Do not remove any protection devices which require the use of special tools.
- ◆ Do not wash the machine with corrosive substances or with pressurized water.
- ◆ Send the machine to a Service Center nearby for servicing after 200 hours of use.
- ◆ To prevent the formation of scale in the solution tank filter, do not fill the tank with detergent solution many hours before using the machine.
- ◆ Before using the machine, check that all the hatches and covers are positioned as shown in this Manual.
- ◆ Before moving the recovery tank, empty the water.
- ◆ When disposing of consumption materials, observe the laws and regulations in force.
- ◆ When your machine has reached the end of its long working life, dispose of the materials it contains in an appropriate manner (e.g. oil, batteries and electric parts), and bearing in mind that the machine itself was constructed using 100% recyclable materials.

## I . MACHINE PREPARATION

### HANDLING THE PACKED MACHINE

The machine is fixed to a pallet, which is specially designed for forklift handling..

Overall dimensions of the package :

L: 1470mm

W: 630mm H:

1200 mm

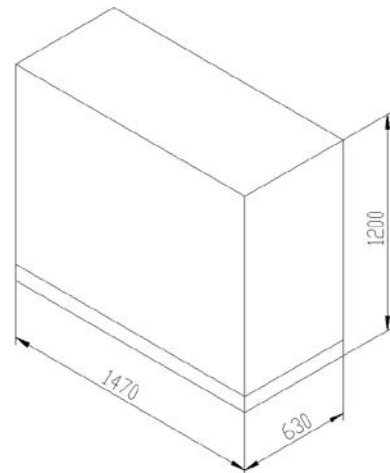

### HOW TO UNPACK THE MACHINE

- 1.Remove the outer packaging ( as figure )
- 2.The machine is fixed to the pallet with wedges and belts which block the wheel.
- 3.Remove these belts.

4. Get the machine down from the pallet.



Keep the pallet for any future transport needs.

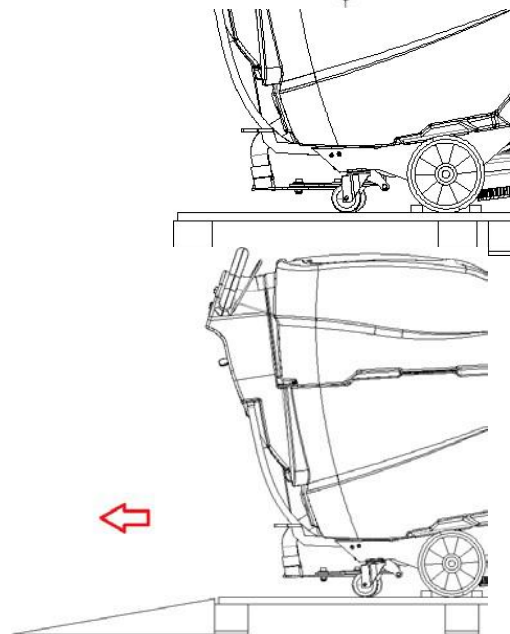

**OVERALL INTRODUCTION**

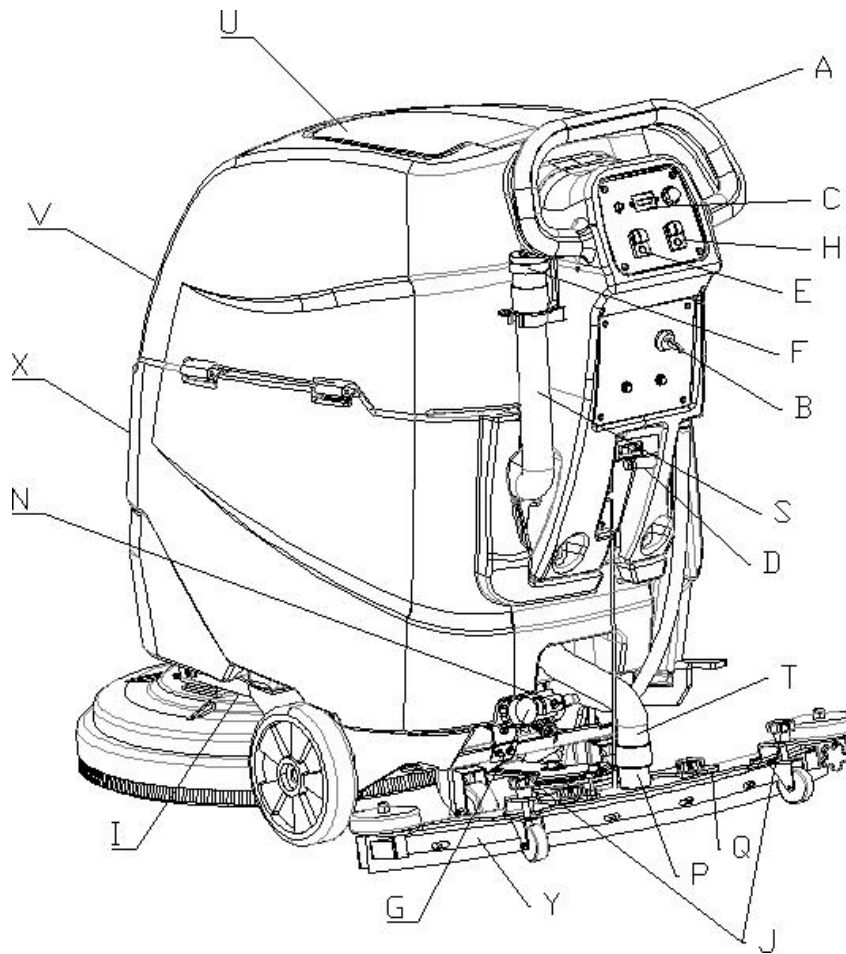

- |                                   |                         |                         |                              |
|-----------------------------------|-------------------------|-------------------------|------------------------------|
| A : handle                        | B : Key switch          | C : Voltmeter           | D : Squeegee lifting rod     |
| E : brush switch                  | F : Cap of the drainage | G : Filter              | H : Squeegee switch          |
| I : magnetic valve                | J : Angle adjuster      | K : Brush               | L : Jumper cables            |
| M : Battery connector<br>(female) | N : Water tap           | O : Water level<br>tube | P : Squeegee fixed<br>handle |
| Q : Squeegee                      | R : Filter spongy       | S : Sewage pipe         | T : Suction pipe             |
| U : Cover                         | V : Recovery tank       | W : Skirt               | X : Solution tank            |
| Y : Rear rubber                   | Z : Batteries           |                         |                              |



### INSERTING THE BATTERIES ( apply to A-5B )

The batteries should be correctly placed in the battery box below the recovery tank.

The type of battery must comply with CEI21-5 description. Inserting the batteries as follows ( as figure ) :

1. Raise the recovery tank backwards.
2. House the batteries in the compartment, positioning the poles “+” and “-“opposite each other.

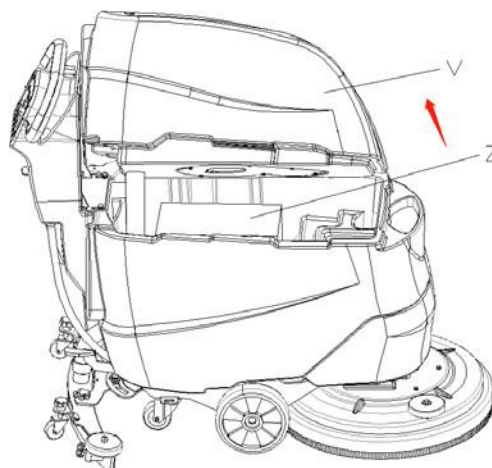

### CONNECTING THE BATTERIES ( AS FIGURE )

Connect the charger to the battery connector cable. The battery connector is put together with this Manual in one package.



You are advised to have the electric connections made by a professional. Any error would harm the operator and damage the machine.

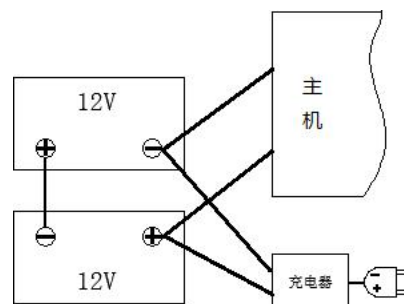

### TYPE OF BATTERY

To power the machine there are three types of batteries below :

- Lead-acid battery composed of liquid plumbic acid, called WET Battery.
- Liquid electrolyte lead traction batteries, called AGM Battery.
- Sealed traction batteries with gas recombination or gel technology, called GEL Battery.

OTHER TYPES MUST NOT BE USED

Max size of the battery : Length=335mm Width=180mm Height=218mm

Max weight of the battery : 36kg.

Connect two 12V batteries in series to obtain a voltage of 24V on the clamps. The connection must be operated by a qualified,

### BATTERY MAINTENANCE

For maintenance and recharging, respect the instructions provided by the battery manufacturer.

Particular attention must be paid when choosing the battery charger, if not supplied, since there are different kinds according to the type and capacity of the battery.

## BATTERY DISPOSAL

When the battery reaches the end of its working life, it must be disconnected by expert, trained personnel, then lifted to remove it from the battery compartment.



Exhausted batteries are classified as dangerous waste. When disposing, observe the laws and regulations in force.

## RECHARGING THE BATTERIES

In order not to cause permanent damage to the batteries it is essential to avoid their complete discharge: arrange the recharge within a few minutes of the switching on of the flashing "discharged batteries" signal.

NOTE: never leave the batteries completely discharged, even if the machine is not being used. While recharging, keep the recovery tank raised, supporting it with the cable, as shown in the figure. Check the battery charger is suitable for the batteries installed, in terms of both capacity and type.

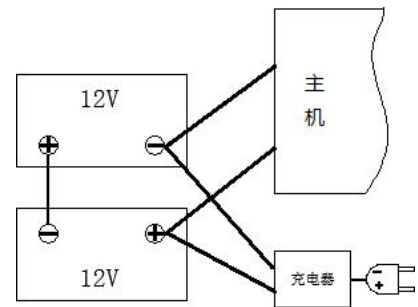

Caution, shock



Caution, Danger of exhalation of gas and corrosion



Danger of fire: do not go near with free flames



## VOLTMETER

The battery charging status display table has 10 segments of LED light display. 3 colors of light column. These colors represent different charging states.

10 section = 100%

Green = plenty of electricity

Yellow = the remaining 30% of the battery

Red = low power, need to be charged.

You are advised that when you use the AGM battery, the yellow indicator lights up, you can use the our company's smart charger for charging.

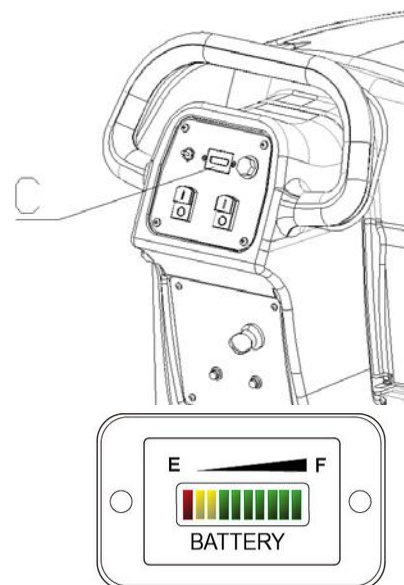

### ASSEMBLING THE SQUEEGEE

For packaging reasons, the squeegee is supplied disassembled from the machine, and must be assembled on the machine connection. Fix the squeegee to the Support frame assembly (Q) with bolt as figure. Then connect the Suction pipe (T) to the squeegee

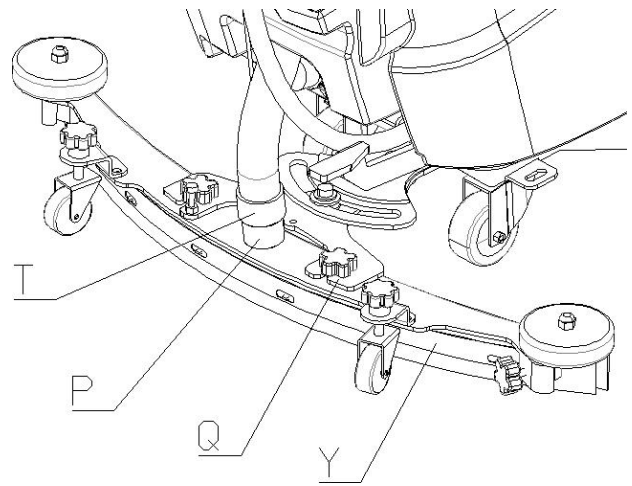

### ADJUSTING THE HEIGHT OF SQUEEGEE

Adjust the height according to the rubber as follows:

Rotate the adjuster (J) clockwise to raise the squeegee, anticlockwise on the contrary.

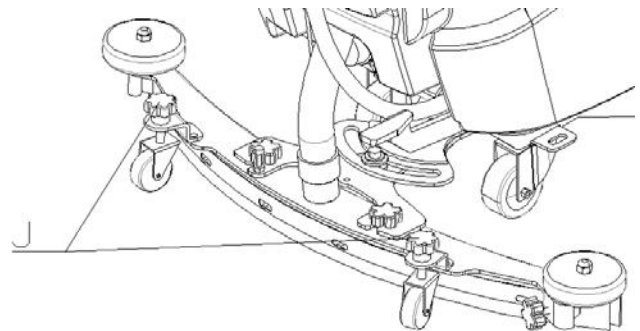

Rotate the adjuster of both sides simultaneously to keep the squeegee parallel with the ground.

## RECOVERY TANK

Rotate the recovery tank as far as it will go, using the side handle.

Check the suction tube (T), the drainage tube(S) and the recovery tank is correctly connected.

Check the suction tube (T) and the squeegee (P), the drainage tube(S) and the cap of drainage tube (F) is correctly connected further.

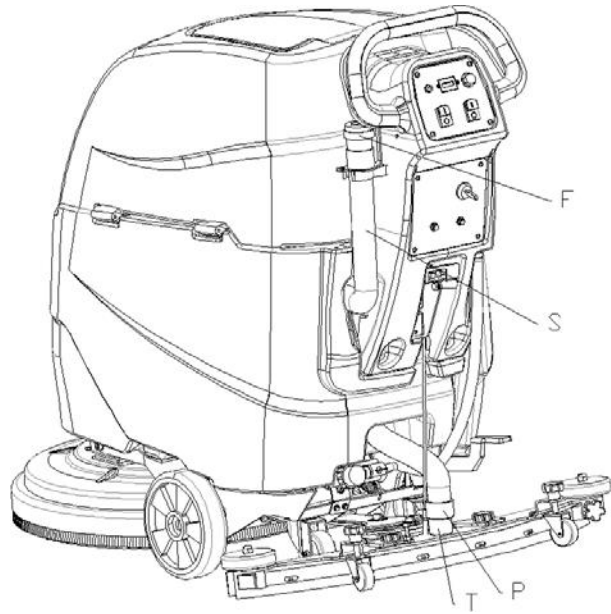

## SOLUTION TANK

Remove the front inlet cap (R), fill it with clean water.

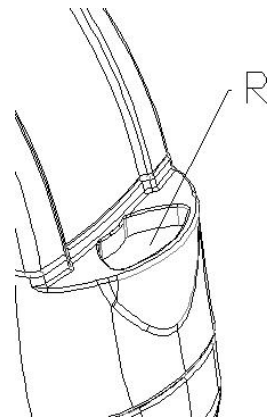

## CLEAN WATER

Fill the solution tank with clean water at a temperature not exceeding 50°C. Add the liquid detergent to the tank in the concentration and manner indicated on the detergent manufacturer's label. The formation of excess foam could damage the suction motor, so use only the minimum amount of detergent necessary. Cover the tank with cap(R).



You are advised to always use low foam detergents and add a little anti-foam reagent to solution tank. Do not use pure acids !

### ASSEMBLING THE BRUSH

1. At first, turn the key (B) to position "0" to turn off the power.



This operation must be carried out after switch off the power supply to protect your hands.

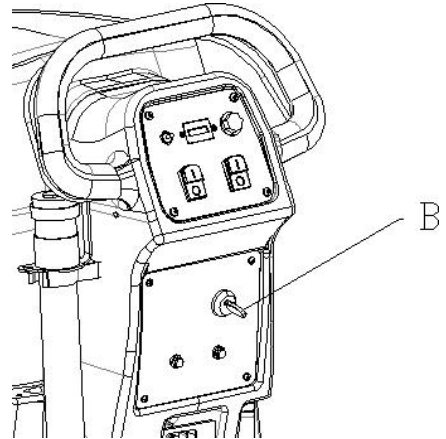

2. With the base up, place the brushes into the plate housing beneath the base, turning the brushes until the three pins enter the niches in the plate itself; turn until the pin is pushed towards the coupling spring and is locked into place. The figure shows the rotation direction for coupling the brush

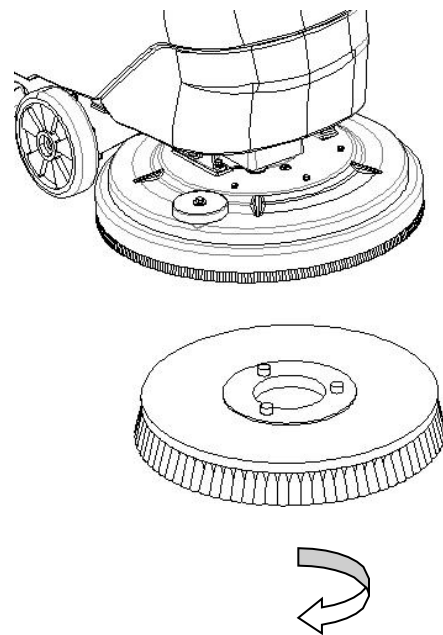

## II.WORK

### PREPARING TO WORK

1. Connect the connector (M) to the batteries;
2. Turn the key (B) of the main switch to position "1" .The monitor (H) on the instrument panel will immediately come on;

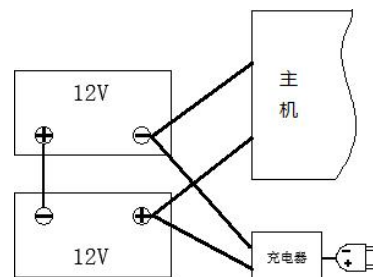

3. Rotate the water tap (N) to adjust the flow. Select an appropriate level. The water falls automatically while the brushes are turning. You are advised to adjust the level according to the movement speed and the type of floor and dust;

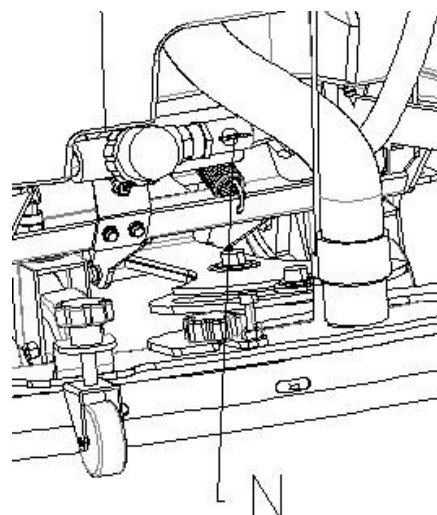

4. Lean the head of the machine toward the front and lower the base;
5. Lower the squeegee, rotating the squeegee lifting lever (D).

### WORKING

Walk forward: Press the brush switch and Squeegee switch.

Then hold the handle with the machine working



When making even brief reverse movements, check the squeegee is raised.

During the first meters, check there is sufficient solution and that the squeegee dries perfectly. The machine will now start to work efficiently until the detergent solution runs out.

When there is an operation risk. Please turn down the power including the Key switch. Restart the machine after trouble shooting.

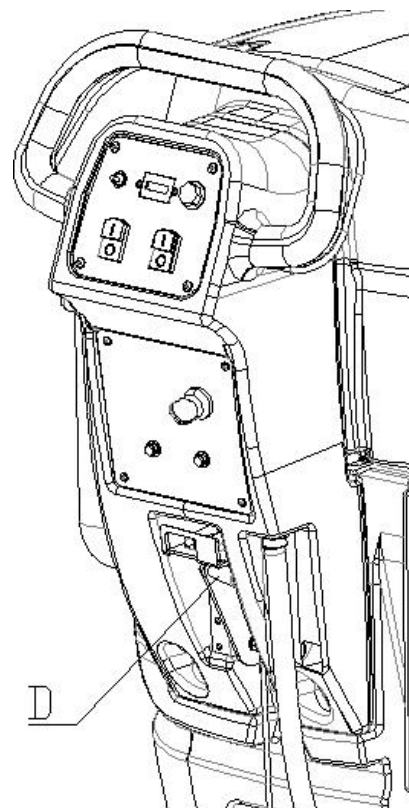



## OVERFLOW DEVICE

The machine is fitted with a float which intervenes when the recovery tank is full, causing the suction tube to close. In this case, to avoid harming the motor, it is **MUST** to empty the recovery tank,



This operation must be carried out using gloves to protect against contact with dangerous solutions.

## AT THE END OF THE WORK

1. Press the brush pedal to rise the brush.
2. Raise the squeegee by means of lifting lever (D).
3. Bring the machine to the place provided for draining the water.
4. Turn the key switch (B) to "OFF" to switch off the machine.
5. Remove the drainage tube (S) from its compartment.
6. Unscrew the drainage cap (F) and empty the recovery tank.

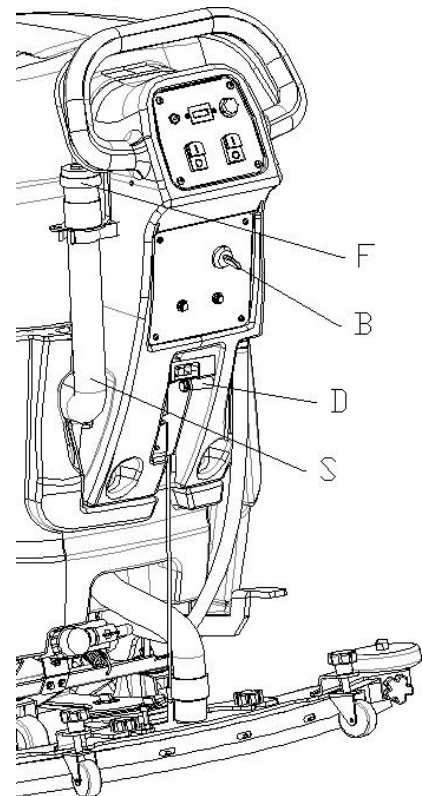

These operations must be carried out using gloves to protect against contact with dangerous solutions

7. Disassemble the brushes and clean them with a jet of water (to disassemble the brushes, see "DISASSEMBLING THE BRUSHES" below).

### III. DAILY MAINTENANCE

#### CLEANING THE RECOVERY TANK

1. Remove the Sewage pipe(S)
2. Remove the cap (F) and empty the tank.



These operations must be carried out using gloves to protect against contact with dangerous solutions

3. Rinse the inside of the tank well with a jet of water, then empty the tank ;
4. Rinse all the elements with a jet of water to make clean
5. Reassemble all the elements

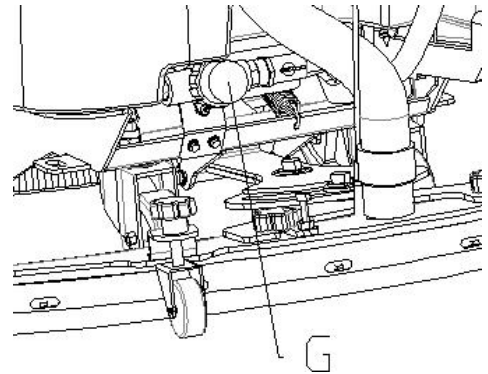

#### CLEANING THE SUCTION FILTER

1. Remove the suction filter (G) from its seat.

Use a jet of water to clean the walls and base of the filter.

2. Reassemble all the elements.

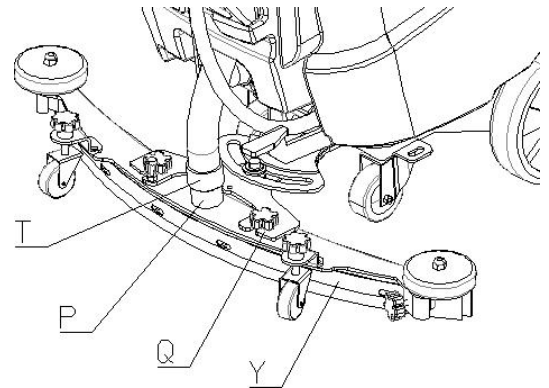

#### CLEANING THE SQUEEGEE

Check the squeegee is always clean, for better drying results, to clean it you must:

1. Remove the tube (T) from the squeegee.
2. Release the Squeegee fixed nut, then take down the squeegee (Y)
3. Carefully clean the inside of the squeegee (Q) and rubbers.
4. Every week, or whenever suction seems to be unsatisfactory, check the squeegee tube is not obstructed.

To clean it

5. Reassemble all the elements again.

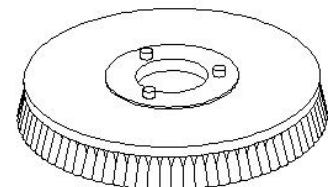
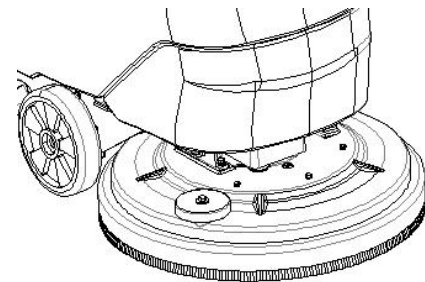

#### DISASSEMBLING THE BRUSH

1. Get the base up;
2. Turning the brush to the direction that The figure shows the rotation;
3. If you will not use the machine long time. Please disassembling the brush, then keep it clean and dry.

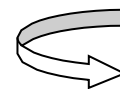



## CLEANING THE BATTERY BOX

Whenever keep the battery and box clean with duster. Check out jumper cables and insulation base to make sure connecting firmly. If not it will lead to the jumper cables heat. Then the battery will be under the influence of that.



This operation must be carried out using gloves to protect against contact with dangerous solutions.



Danger of exhalation of gas and leakage of corrosive liquids



Danger of fire: do not go near with free flames.

## IV. WEEKLY MAINTENANCE

1. Add grease or lubricating oil to the sliding part regularly

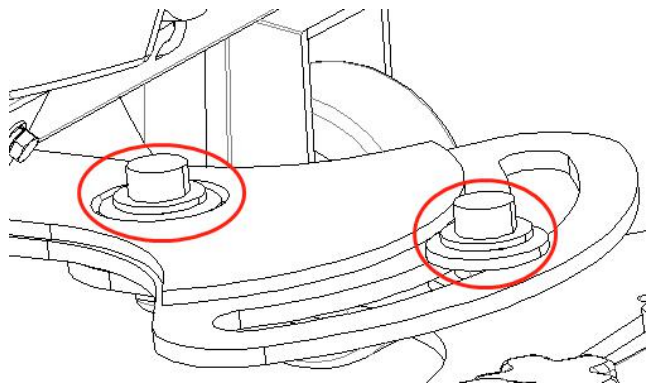

support frame assembly

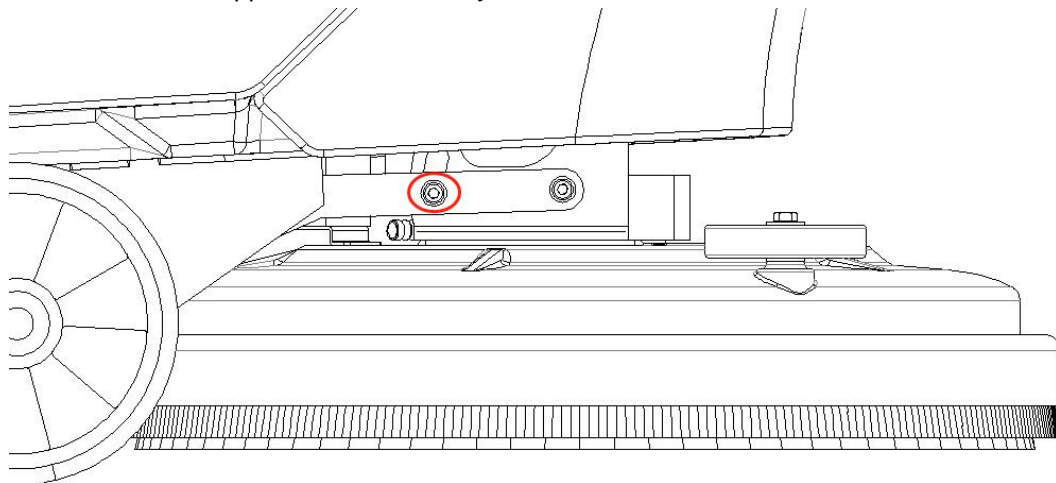

nose assembly

## REPLACING THE SQUEEGEE RUBBERS

Check the state of wear and tear of the squeegee rubbers and, if necessary, replace them as below:

- 1 . Remove the tube (T) from the sleeve (P) on the squeegee.
- 2 . Rotate the nut on the squeegee.
- 3 . Unthread the squeegee (Y).
- 4 . Loosen the screw (4) that block the rubber-pressing blade and take down the plate (5) stainless steel.
- 5 . Reassemble the rubber (6).

Then reassemble all the elements

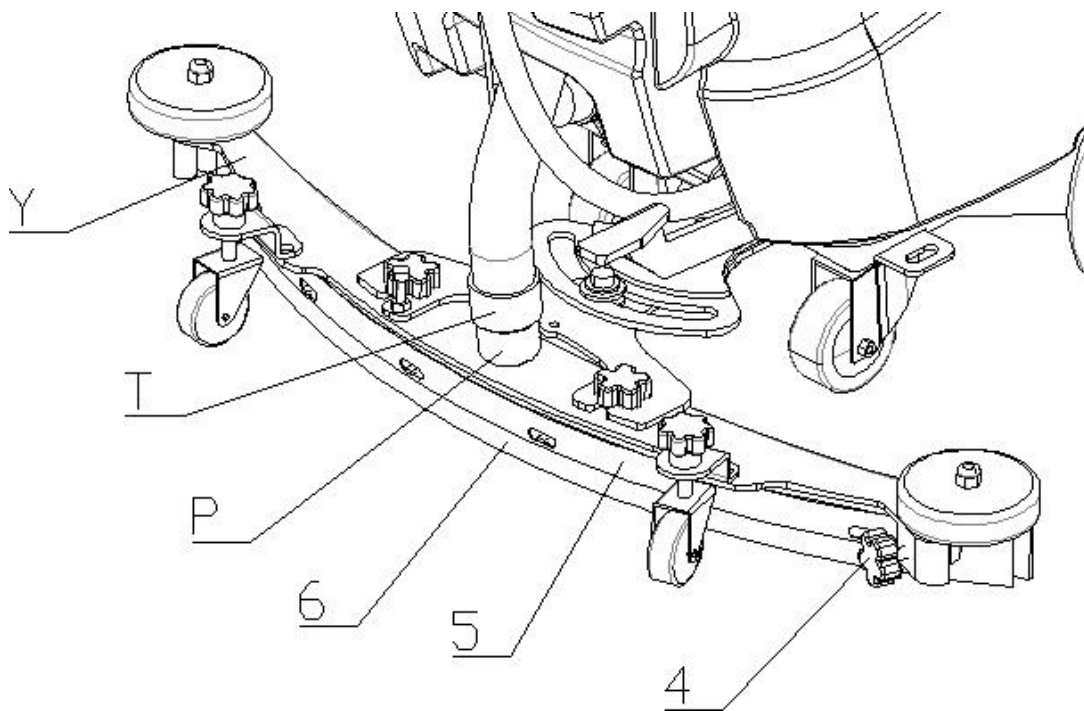

## V. TROUBLE SHOOTING

Before you take it to repair or call our customer service to help, you should check out those problems.

Phenomena	Reason	Method
Brush motor can't work	<ol style="list-style-type: none"> <li>1. Check out whether electricity is good ;</li> <li>2. Check out whether motor switch is on ;</li> <li>3. Check out whether the voltage is good.</li> </ol>	<ol style="list-style-type: none"> <li>1. Plug in the power and make sure the fuses are normal work ;</li> <li>2. Turn on the switch of motor ;</li> <li>3. The batteries are fully charged</li> </ol>
Water can't come out from the brush or slightly	<ol style="list-style-type: none"> <li>1. Filter or joint is clogged ;</li> <li>2. Clean the drier ground at first ,so the water can't catch up with it</li> <li>3. The solenoid valve is clogged or rejected.</li> </ol>	<ol style="list-style-type: none"> <li>1. Take down the filter and joint ,then wash them ;</li> <li>2. If the ground is drier, you must spray it extra ;</li> <li>3. Take down the solenoid valve, then wash it .</li> </ol>
Suction abate	<ol style="list-style-type: none"> <li>1. The cover of recovery tank is not sealed ;</li> <li>2. Hose clamp loose ;</li> <li>3. Suction Motor loose or defection ;</li> <li>4. The suction hose is not completely blocked ;</li> <li>5. Battery low.</li> </ol>	<ol style="list-style-type: none"> <li>1. Check the seal rubber of cover and make sure the cover will be sealed</li> <li>2. Check out and lock the hose clamp ;</li> <li>3. Make sure the motor install well and tighten the screw</li> <li>4. Dredge the pipe</li> <li>5. Charge the batteries.</li> </ol>
Fuse crack of battery terminal and cable heating	<ol style="list-style-type: none"> <li>1. Cable can't tightened well that lead to bad contact ;</li> </ol>	<ol style="list-style-type: none"> <li>1. Tighten the screw ;</li> </ol>
Water absorption is not clean	<ol style="list-style-type: none"> <li>1. Suction motor do not work ;</li> <li>2. Suction hose is blocked ;</li> <li>3. The squeegee is blocked with something ;</li> <li>4. The squeegee is totally worn-out ;</li> <li>5. The height of the squeegee is not suitable.</li> </ol>	<ol style="list-style-type: none"> <li>1. Check out the motor ( according to above ) ;</li> <li>2. Clean them ;</li> <li>3. Clean them ;</li> <li>4. Change squeegee blade rubbers ;</li> <li>5. Adjust the height of the squeegee.</li> </ol>
The brush do not clean well	<ol style="list-style-type: none"> <li>1. The motor of the brush can not work ;</li> <li>2. Dirt is too stubborn ;</li> <li>3. Brush is serious abrasion ;</li> <li>4. Something twine round the brush.</li> </ol>	<ol style="list-style-type: none"> <li>1. Check out the motor ;</li> <li>2. Use appropriate cleaning fluid ;</li> <li>3. Change the brush ;</li> <li>4. Clean them.</li> </ol>

## **VI. CHOOSING AND USING THE BRUSHES**

### **POLYPROPYLENE BRUSH ( PPL )**

Used on all types of floors. Good resistance to wear and tear, and hot water (no greater than 60°C). The Polypropylene brush is non-hygroscopic and therefore retains its characteristics even when working in wet conditions.

### **NYLON BRUSH**

Used on all types of floors. Good resistance to wear and tear, and hot water (no greater than 60°C). The Nylon brush is hygroscopic and easy-extended; as a result it cannot retain its characteristics when working in wet conditions.

### **ABRASIVE BRUSH**

The bristles of this type of brush are extremely hard. It is used to clean very dirty floors. To avoid floor damage, work only with the pressure strictly necessary.

### **STEEL BRUSH**

It is made up of steel wire and artificial fiber blends and used to clean rough roads, floors with big joints or dirt which is difficult to clean up.

### **THICKNESS OF THE BRISTLES**

Thicker bristles are more rigid and are therefore used on smooth floors or floors with small joints.

On uneven floors or those with deep joints, it is advisable to use softer bristles which can enter the gaps more easily.

Remember that when the bristles are worn and therefore too short, they will become rigid and are no longer able to penetrate and clean deep down. In this case, like with over-large bristles, the brush tends to jump.